

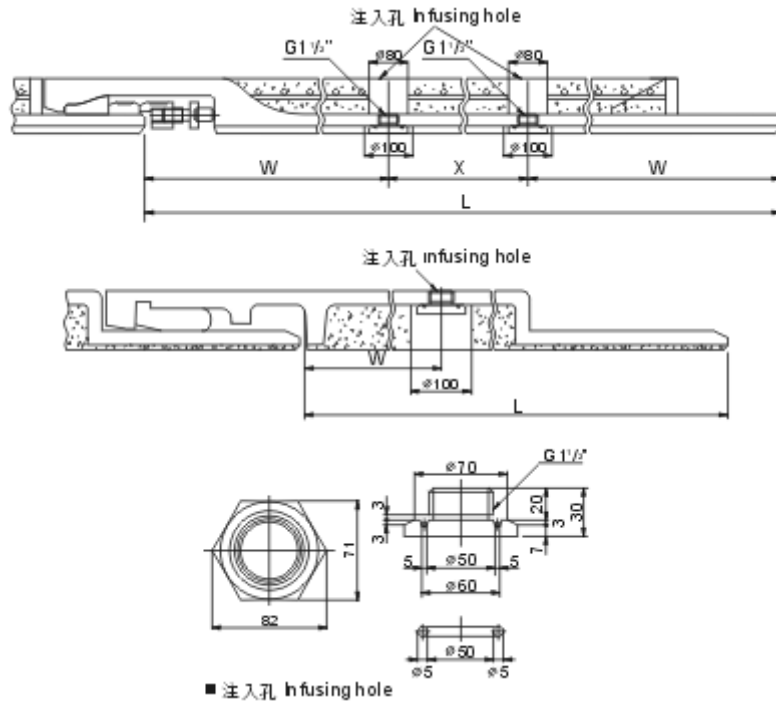

Infusing Hole for Jacking Method Ductile Iron Pipe



Unit : mm

DN	Effective Length		Dimensions	
	L		W	X
800	2500		1200	-
	6000		1500	3000
900	2500		1200	-
	6000		1500	3000
1000	2500		1200	-
	6000		1500	3000
1100	2500		1150	-
	6000		1500	3000
1200	2500		1150	-
	6000		1500	3000
1350	2500		1150	-
	6000		1500	3000
1500	2500		1100	-
	6000		1500	3000
1600	2500		1100	-
	4000		1000	2000
	5000		1250	2500
1650	2500		1100	-
	4000		1000	2000
	5000		1250	2500
1800	2500		1100	-
	4000		1000	2000
	5000		1250	2500
2000	2500		1100	-
	4000		1000	2000
	5000		1250	2500

Note: Generally, Jacking Method DIP don't need to manufacture the infusing hole, depend on the geologic strata property if must infuse into slippery reduces the pipeline propulsion resistance or must infuses in to fill the material to keep earth's surface from falling to sink...etc., please consult us.